

# **Type Test Procedure for OPGW Cable**

The type test procedures to be conducted on the OPGW cable are as follows:

S.No.	TEST NAME	APPLICABLE STANDARD	TEST RESULT (PASS / FAIL)
1	Water Ingress Test	IEEE 1138-2021 Method 6.5.3.5	
2	Seepage of Filling Compound Test	IEEE 1138-2021 Method 6.5.3.6	
3	Short Circuit Test	IEEE 1138-2021 Method 6.5.3.3	
4	Aeolian Vibration Test	IEEE 1138-2021 Method 6.5.3.1	
5	Galloping Test	IEEE 1138-2021 Method 6.5.3.2	
6	Cable Bend Test	IEEE 1138-2021 Method 6.5.2.3	
7	Sheave Test	IEEE 1138-2021 Method 6.5.2.1	
8	Crush Test	IEEE 1138-2021 Method 6.5.2.2	
9	Twist Test	IEEE 1138-2021 Method 6.5.2.4	
10	Creep Test	IEEE 1138-2021 Method 6.5.1.1	
11	Strain Margin Test	IEEE 1138-2021 Method 6.5.1.3	
12	Stress Strain Test	IEEE 1138-2021 Method 6.5.1.2	
13	Temperature Cycling Test	IEEE 1138-2021 Method 6.5.3.7	
14	Corrosion (Salt Spray Test)	IEEE 1138-2021 Method 6.5.3.8	
15	Ultimate Tensile Strength Test	IEEE 1138-2021 Method 6.5.1.4	
16	Lightning Arc Test	IEEE 1138-2021 Method 6.5.3.4	
17	DC Resistance Test	IEEE 1138-2021 Method 6.5.1.5	

**Note:** All Hardware fittings to be used during type test shall be as per approved DRS/ drawings applicable for offered OPGW cable to be type tested.

**Reference docs:**

1. Approved DRS / Drawings of OPGW
2. Approved DRS / Drawings of OPGW fittings
3. Applicable standard. (IEEE 1138-2021)
4. Section -03– Technical specifications

**TYPE TEST PROCEDURE FOR OPGW CABLE**

(1) **Test Name: Water Ingress Test**

**Final Customer: Power Grid Corporation of India Limited, India.**

**Project Name:**

**Manufacturer:**

**Cable Type:**

**Standard: IEEE 1138-2021 Method 6.5.3.5**

**CLASSIFICATION:** Operation/environmental/ mandatory

**INTENT**

The intent of the Water Ingress Test is to determine if the quantity of fluid blocking compound in the OPGW cable is sufficient and uniformly distributed to inhibit water from migrating through the optical fiber unit. This test is only applicable for those cable designs that utilize a water-blocking compound inside the optical fiber unit. Water ingress into the optical fiber unit can degrade the performance of the optical fibers.

**OBJECTIVE**

To expose a length of fluid blocked optical fiber unit to a head of water to verify that water does not passthrough the unit.

The optical performance of the OPGW cable is not monitored during this test.

**SET-UP**

Water ingress test for OPGW cable that use water-blocking compound is based on the most recent revision of EIA/TIA-455-82, except that the test and retest lengths, if used, shall be 1.0 m.

A 1.0 m section of OPGW cable shall be prepared for this test. All components of the cable shall be removed from the fluid-blocked optical unit that contains the optical fibers.

The fluid-blocked optical fiber unit shall be positioned horizontally with one end attached to the bottom of a suitable tube containing a column of water that is at least 1 m in height using a watertight fitting. A clear, plastic tube is commonly used for this purpose. No part of the fluid-blocked component shall be above horizontal. The fitting shall not restrict water from entering the optical fiber unit. A collection dish, or equivalent means of detecting water, shall be placed under the open end of the optical fiber unit to collect any water that may pass through it.

Optical measurements are not required for this test.

The optical fiber unit and collection dish shall be visually checked for water. The start and completion times shall be recorded. No electronic measurements are required for this test.

**PROCEDURE**

The reservoir, or tube, shall be filled with water such that the head above the optical fiber unit is least 1.0m. The water shall be maintained at this level for at least one hour. During, and at the conclusion of, the one hour period, the open end of the optical fiber unit shall be visually checked for water.

**ACCEPTANCE CRITERIA**

No water shall leak through the open end of the 1.0m sample. If the first sample fails, one additional 1.0 m sample, taken from a section of OPGW cable immediately adjacent to the first sample, may be tested for acceptance.

OBSERVATIONS, IF ANY:

**TEST RESULT:** The OPGW cable met/not met the acceptance criteria for Water Ingress test.

(TESTED BY)  
Sign & Date

(WITNESSED BY)  
Sign & Date

**TYPE TEST PROCEDURE FOR OPGW CABLE**

**(2) Test Name: Seepage of Water-blocking Compound Test**  
**Final Customer: Power Grid Corporation of India Limited, India.**  
**Project Name:**  
**Manufacturer)**  
**Cable Type:**  
**Standard: IEEE 1138-2021 Method 6.5.3.6**

**Classification:** In-service/environmental/conditional

**Intent**

The intent of the Seepage of Water-blocking Compound Test is to determine if the water-blocking compound in the OPGW cable is vulnerable to flowing at elevated temperatures.

NOTE-This test is only applicable for those cable designs that utilize a fluid-blocking compound. The test is to demonstrate that the water blocking compound is not likely to seep.

**Objective**

- a) To subject the OPGW cable to an elevated temperature that may cause the fluid-blocking compound to drip or otherwise leak from the optical fiber unit.
- b) The optical performance of the OPGW cable is not monitored during this test.

**Set-up**

The general arrangement for the seepage of water-blocking compound test is shown in Figure 2.1. The test shall be performed in accordance with TIA/EIA-455-81, except that an optional preconditioning cycle be used.

Five OPGW cable samples, each  $30.0 \text{ cm} \pm 0.5 \text{ cm}$  in total length shall be prepared. All metallic strands are cut back  $13.0 \text{ cm} \pm 0.25 \text{ cm}$  from one end to expose the fluid-blocked optical fiber unit(s). The sample ends shall not be blocked or sealed to restrict the fluid flow. The samples are suspended vertically from a support frame. Small, lightweight collection dishes are placed directly under each sample to collect any fluid-blocking compound that may drip from the optical fiber unit. The samples shall be shielded from any air circulation in the chamber. The temperature in the chamber shall be measured using a thermocouple placed near the support frame close to the samples.

Optical measurements are not required for this test.

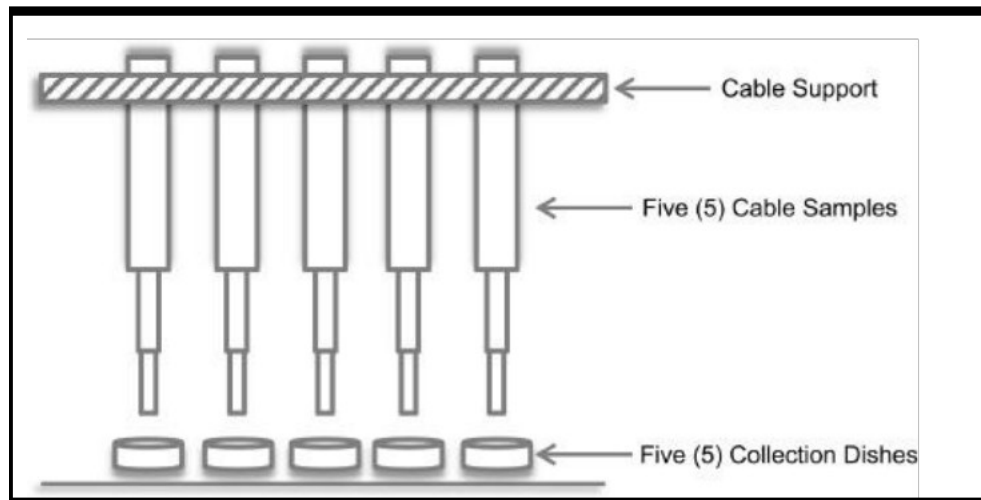

**Figure 2.1—General arrangement for seepage of water-blocking compound test**

## Procedure

The temperature chamber shall be preheated to at least 65 °C.

The five samples and collection dishes shall be weighed and recorded using a scale having an accuracy of at least  $\pm 0.001$  g. The support frame, with the covered samples, shall be placed in the chamber.

Optional preconditioning: A clean dish shall be placed directly under the test specimen. The sample shall be suspended vertically for one hour at  $65\text{ °C} \pm 2\text{ °C}$ , unless otherwise specified. After preconditioning, the samples are removed from the chamber and the dishes weighed and recorded to measure the quantity of water-blocking compound that may have dripped during the preconditioning period. The preconditioning limit is the smaller of 0.5% of the total cable specimen weight or 0.5 g. Presence of a greater amount of material in the glass dish constitutes failure. If any fluid is collected in dish during preconditioning, replace it with a clean dish.

After the optional or one hour preconditioning period, clean dishes are placed under the samples and returned to the chamber. After 23 additional hours (24 h total), the samples are again removed from the chamber and the dishes weighed and recorded. Unless otherwise specified, report “NoFlow” for measured quantity changes less than or equal to 0.005 g.

Changes in weight of  $\pm 0.001$  g are not considered due to leakage of water-blocking compound.

**Acceptance criteria**

At the end of 24 h, the water-blocking compound shall not flow (drip or leak) at 65 °C. Unless otherwise specified, the five cable samples shall be permitted a maximum flow quantity of 0.050 g.

If the flow quantity from one of the five initial cable samples exceeds 0.050 g, but is less than 0.100 g, prepare five new cable samples and retest. The test shall be considered successful if none of the second batch of samples have flow quantities greater than 0.050 g.

**OBSERVATIONS, IF ANY:**

**TEST RESULT:** The OPGW cable met/not met the acceptance criteria for Seepage of Filling Compound test.

**(TESTED BY)**

Sign &amp; Date

**(WITNESSED BY)**

Sign &amp; Date

**TYPE TEST PROCEDURE FOR OPGW CABLE****(3) Test Name: Short Circuit Test****Final Customer: Power Grid Corporation of India Limited, India.****Project Name:****Manufacturer:****Cable Type:****Standard: IEEE 1138-2021 Method 6.5.3.3****Classification:** In-service/electrical/mandatory**Intent**

The intent of the short-circuit test is to subject the OPGW cable to a simulated short-circuit condition that represents an anticipated fault current. The intent is to determine if the resulting high temperatures adversely affected the optical signals or damages the cable strands such as permanent bird caging, loss of tensile strength through annealing of metallic components, or melting or softening of non-metallic components.

NOTE—Due to the potential loss of tensile strength of the cable when temperatures exceed 220 °C, a tensile strength test following the Short-circuit Test is recommended on the test sample to verify it meets the vendor's specification for UTS.

**Objective**

- a) To verify the mechanical performance of the OPGW cable when subjected to the specified short circuit conditions.
- b) To verify the optical performance of the OPGW cable when subjected to the specified short- circuit conditions.

**Set-up**

A typical set-up for the Short-circuit Test is shown in Figure 3.1.

**Apparatus**

Two OPGW cable samples shall be used for this test. One sample is used to monitor the performance of the optical fibers and to observe any physical damage that might occur during the test. The second sample is used to measure the temperature at several points in the cross-section of the cable. If placed outdoors, the samples shall be positioned such that effects due to wind, solar radiation, etc., are the same on the samples.

The cables shall be electrically connected in series so that they are subjected to the same short-circuit current. Suitable means, such as low-level circulating ac current, shall be used to maintain the temperature of the cables as measured by the temperature sample to the manufacturers specified reference temperature for short-circuit capacity of the cable.

### **Optical sample**

For optical attenuation measurements, the optical cable sample shall be prepared according to Table 3.2.

The length of cable between the current injection points shall be at least 10 m. The optical fibers shall be terminated beyond each dead-end clamp. A suitable means shall be used to tension the cable from 15% to 20% of the UTS of the OPGW cable when the cable is at the manufacturer's specified reference temperature. A suitable device such as a dynamometer or load cell shall be used to measure the tension in this sample.

### **Temperature sample**

The temperature in this sample shall be measured at three locations or more. This is normally achieved using fast-responding thermocouples. However, other techniques that provide reliable and accurate data may be used if available. If thermocouples are used, they shall be spaced approximately 1 m apart, at the midpoint of the sample. They shall be installed in the cable to provide the temperature at the following points in the sample:

- a) Located where the maximum temperature rise is expected. Depending on the design of the OPGW cable, this would normally be aluminum component(s) such as the wires, an aluminum tube, or the slotted central core, if applicable.
- b) Located where the second highest temperature rise is expected. This may involve an aluminum component and a steel component or two steel components.
- c) Located inside the optical unit with the intent of measuring the temperature of the optical fibers.

Thermocouples may be "pinched" between two adjacent components. It is recognized that the thermocouple will be influenced by any components making contact with the junction.

The thermocouples shall be isolated from other instrumentation to prevent electrical interference. A suitable means (e.g., turnbuckles, hydraulic cylinder) shall be used to tension this cable but it is not necessary to measure the tension.

### **Instrumentation and data acquisition**

For each short-circuit application, or "pulse," a suitable data acquisition system shall record the short circuit current, the optical power readings from the optical sample and the thermocouple readings from the temperature sample.

The aluminum, steel, and non-metallic components of the cable will reach their respective maximum temperatures at different times. Typically, the optical fiber unit will take the longest time. For this reason, the data shall be acquired for sufficient time after each pulse in order to record the maximum temperatures of all components. The temperatures in the metallic components may reach their respective maximums in less than 1 s. For this reason, the data sampling rate shall be fast enough to capture these maximums.

**Procedure**

The cables shall be heated to 40 °C ±5 °C, unless otherwise agreed upon between supplier and user as indicated by the highest reading thermocouple in the temperature sample. All thermocouples shall be maintained at a constant temperature. The optical signals shall be stable for at least 15 min before proceeding.

If required, “preliminary” pulses, not to exceed about 50% of the supplier’s specified short-circuit current value, may be applied in order for the test laboratory to determine the proper electrical parameters. Preliminary pulses are not considered part of the “official” test. If necessary, the optical signals shall be allowed to stabilize after the preliminary pulses before proceeding with the official test. Once stable, the difference between the power meters shall be zeroed 5 min before the first official pulse and shall be considered the start of the official test.

The cable shall then be subjected to five official pulses. For the official pulses, the minimum and maximum values for the electrical parameters are shown in Table 3.3:

**Table 3.3—Electrical parameters**

Parameter	Target value
Fault I <sup>2</sup> t	Minimum kA <sup>2</sup> s specified by supplier
Fault duration	Same as primary protection breaker operation, if known. Otherwise, maximum 0.5 s

The cable shall be allowed to cool (without the use of a water spray) to the specified reference temperature after each pulse as measured by the highest reading thermocouple. The cable will be held at the reference temperature for at least 5 min between pulses.

For each pulse, the fault current and duration may vary slightly from the target values. The objective is to achieve the I<sup>2</sup>t level for each pulse. To recognize the practical issues of performing this test, the following allowances are made. The average of the five pulses shall equal or exceed the minimum I<sup>2</sup>t level specified by the supplier. However, no single pulse shall be less than 95% of the minimum I<sup>2</sup>t level.

The optical sample shall be visually inspected for birdcaging or other damage periodically throughout the test. Because the cable components can be disturbed when the thermocouples are installed, observations made on the temperature sample are not considered official.

After the final pulse, the optical and temperature data shall continue to be acquired for at least 15 min after the thermocouple with the highest reading has returned to the reference temperature. Final optical and temperature readings and observations of the cable shall be taken at this time. This designates the official end of the short-circuit test.

The optical cable sample shall be dissected after the test. Attention shall be paid in particular to the sections of cable closest to the terminating hardware, and at the midpoint of the span. Each separable component of the cable shall be separated and inspected for excessive wear, discoloration, deformation, or other signs of breakdown.

### **Acceptance criteria**

- a) Any cracking or breaking of any component of the optical sample shall constitute failure. This assessment is made with the naked eye.
- b) There shall be no bird-caging of any of the strands of the optical sample. Bird-caging is defined as one or more cable strands that permanently protrude greater than one strand diameter from the normal cable geometry. A strand will be considered to have bird-caged if light can be seen between the protruding strand and the cable. This observation will be made after the cable has cooled to the reference temperature after the last pulse. Temporary bird-caging during the pulses shall not constitute failure.
- c) There shall be no permanent increase in optical attenuation greater than 0.05 dB/test fiber km at nominally  $1550 \text{ nm} \pm 20 \text{ nm}$  for single-mode fibers.
- d) If specified, the maximum temperature of any metallic component shall not exceed the manufacturers' value at any time during the test. Additionally, the temperature inside of the fiber unit shall not exceed 180 C at any time during the test. Higher temperatures may be allowed if agreed upon between manufacturer and end user.
- e) Any excessive wear, discoloration of fibers, deformation, or other signs of breakdown shall constitute failure.

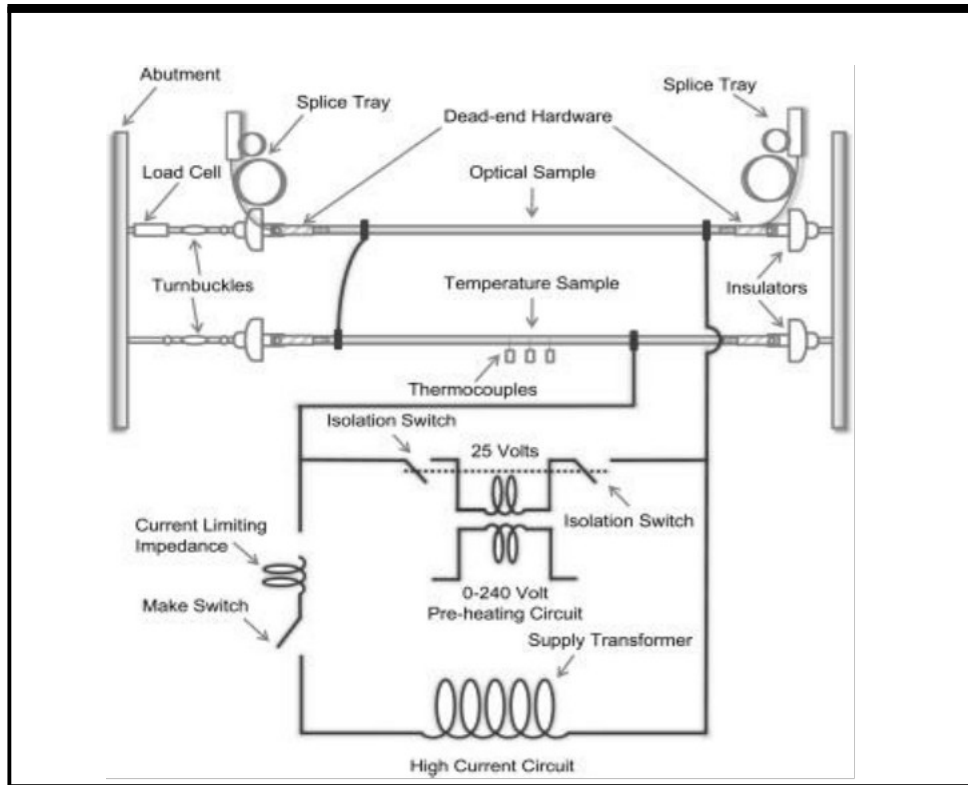

Figure 3.1—Electrical circuit for short-circuit test—Example

**OBSERVATIONS, IF ANY:**

**TEST RESULT:** The OPGW cable met/not met the acceptance criteria for Short Circuit test.

**(TESTED BY)**

Sign & Date

**(WITNESSED BY)**

Sign & Date

**TYPE TEST PROCEDURE FOR OPGW CABLE****(4) Test Name: Aeolian Vibration Test****Final Customer: Power Grid Corporation of India Limited, India.****Project Name:****Manufacturer:****Cable Type:****Standard: IEEE 1138-2021 Method 6.5.3.1****Classification:** In-service/mechanical/mandatory**Intent**

The intent of the Aeolian Vibration Test is to subject the OPGW cable and support hardware to simulated conditions. This type of conductor vibration is caused by laminar wind as it passes over bare cable and is a common occurrence in the field. Fatigue damage can occur on the metal components of the cable or hardware at attachment locations. The optical signals may also be adversely affected by Aeolian vibration.

**Objective**

- a) To verify the mechanical integrity of the OPGW cable and the supporting hardware when subjected to simulated vibration conditions.
- b) To verify the optical performance of the OPGW cable when subjected to the specified vibration conditions.

**Set-up**

The set-up for the Aeolian Vibration Test is shown in Figure 4.1.

**Test Apparatus**

The OPGW cable shall be contained between two intermediate abutments. The active span cable length shall be at least 20 m. The passive span cable length shall be approximately half the active span length. Fixed-end abutments shall be used to load and maintain tension in the fiber optic cable.

The dead-end assemblies shall be installed between intermediate abutments. The suspension assembly shall be supported at a height such that the static sag angle of the cable to horizontal shall be  $1.5^\circ \pm 0.5^\circ$  in the active span.

An electronically controlled shaker shall be used to excite the cable in the vertical plane. The shaker armature shall be securely fastened to the cable so that it shall be approximately perpendicular to the cable in the vertical plane. The shaker shall be located in the span to allow a minimum of five vibration loops between the suspension assembly and the shaker.

The cable shall be prepared for attenuation measurements as described in 6.3.

A laser micrometer or other suitable means shall be used to measure the free loop antinode amplitude. The free loop antinode amplitude of the cable shall be measured at the second free loop from the suspension assembly toward the shaker.

A load cell or dynamometer shall be used to measure the cable tension. A thermocouple shall be used to measure the air temperature.

The optical power signals, peak-to-peak free loop amplitude, vibration frequency, number of cycles, cable tension, and air temperature shall be recorded at periodic intervals by a suitable data logging system.

### **Procedure**

The OPGW shall be tensioned to  $25\% \pm 2\%$  of the cable UTS and the exit angles of the cable from the suspension clamp measured.

This tension shall be applied using a cantilever weight arm on one of the end abutments or other suitable means.

The vibration frequency shall be approximately equivalent to that produced by a 4.5 m/s wind (i.e., frequency = 830 divided by the diameter of the OPGW in mm). The actual vibration frequency shall produce standing waves and good system stability. The target free loop peak-to-peak antinode amplitude will be approximately one-third the diameter of the cable. This amplitude shall be maintained at this level in the second free loop from the suspension assembly toward the shaker. The frequency and amplitude may vary slightly during the test; however, the average antinode peak velocity ( $v = \pi \cdot f \cdot Y_{max}$ ) at the completion of the test shall be a minimum of 860 mm/s where  $Y_{max}$  the peak-to-peak free loop antinode amplitude.

The amplitude of the span from the dead end to the shaker and the passive span shall not exceed the amplitude of the span between the shaker and the suspension.

The number of vibration loops shall be counted, and their average loop lengths calculated for each of the three sections of the OPGW. The three sections are: between the dead end and shaker ; between the shaker and suspension ; and in the passive span between the suspension and dead end.

The OPGW shall be subjected to 100 million vibration cycles.

Optical measurements shall be taken for 15 min after the completion of the vibration cycles.

### **Acceptance criteria**

a) Any cracking or breaking of any component of the OPGW cable or the supporting hardware shall constitute failure. This assessment is made with the naked eye.

- b) A permanent or temporary increase in optical attenuation greater than 0.2 dB/test fiber km at nominally 1550 nm for single-mode fibers shall constitute failure.

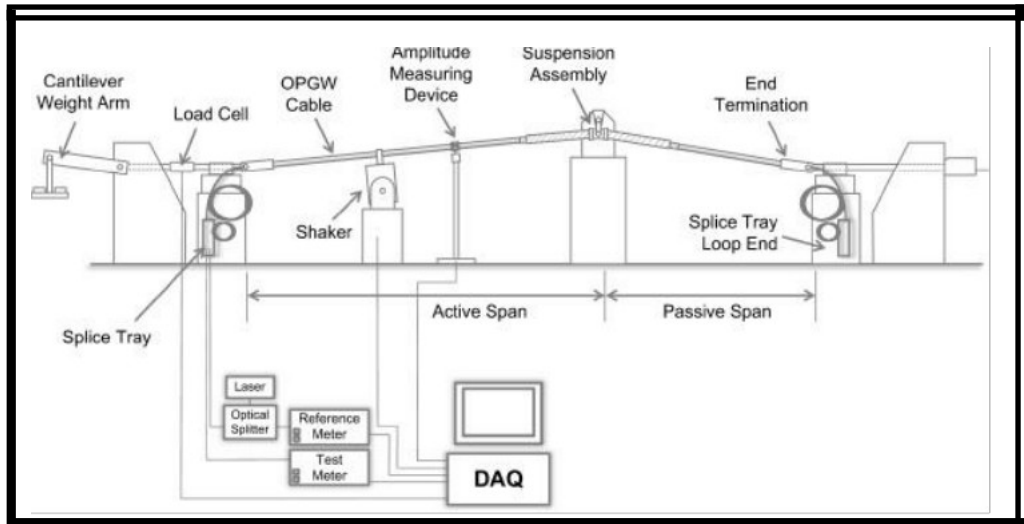

Figure 4.1 —General arrangement for Aeolian Vibration Test

**OBSERVATIONS, IF ANY:**

**TEST RESULT:** The OPGW cable met/not met the acceptance criteria for Aeolian Vibration test.

**(TESTED BY)**

Sign & Date

**(WITNESSED BY)**

Sign & Date

**TYPE TEST PROCEDURE FOR OPGW CABLE****(5) Test Name: Galloping Test****Final Customer: Power Grid Corporation of India Limited, India.****Project Name:****Manufacturer:****Cable Type****Standard: IEEE 1138-2021 Method 6.5.3.2****Classification:** In-service/mechanical/conditional**Intent**

The intent of the Galloping Test is to subject the OPGW cable and support hardware to galloping motions. This type of conductor motion is caused by the wind as it passes over bare or iced cables. This phenomenon typically occurs in areas that experience icing or wet snow. Fatigue or other damage can occur on the components of the cable, hardware, and/or to the structure. The optical signals may also be adversely affected by galloping.

**Objective**

- a) To verify the mechanical integrity of the OPGW cable and the supporting hardware when subjected to simulated galloping conditions.
- b) To verify the optical performance of the OPGW cable when subjected to the specified galloping conditions.

**Set-up**

The set-up for the Galloping Test is shown in Figure 5.1.

**Test apparatus**

The test section shall be contained between two intermediate abutments. The active span cable length shall be approximately 20 m, and the passive span cable length shall also be approximately 20 m. Fixed-end abutments are used to load and maintain tension in the cable. The initial tension shall be approximately 2% of the cable's UTS. This shall be applied using a cantilever weight arm or other suitable means.

The dead-end assemblies shall be installed between the intermediate abutments. The suspension assembly shall be supported at a height such that the static sag angle of the cable to horizontal shall

be approximately than  $1.5^\circ$  in the active span. A calibrated load cell or dynamometer shall be used to measure the cable tension.

A suitable mechanism (e.g., hydraulically driven, motor-drive) shall be used to oscillate the cable in the vertical plane. The mechanism shall be located in the span and attached to the cable to oscillate the cable in a steady, single-loop gallop motion between the suspension assembly and the shaker.

The free loop antinode amplitude shall be measured in the active span at a point midway between the suspension assembly and the dead end. This shall be achieved by manually observing a graduated scale supported next to the cable.

The cable shall be prepared for attenuation measurements as described in 6.2.

The free loop peak-to-peak antinode amplitude, galloping frequency, optical power signals, tension, and number of cycles shall be recorded at periodic intervals. They may be recorded manually or with a data logging system.

### **Procedure**

Reference optical measurements shall be taken while the cable is at tension and prior to starting the test. The difference between the reference and test signals for the initial measurement provides an initial base reading.

The change in this difference during the test indicates the change in the attenuation of the test fiber.

The cable shall be subjected to 100 000 galloping cycles in the single-loop mode. The frequency shall be adjusted such that the cable exhibits steady, single-loop galloping motions in the active span. The free loop peak-to-peak antinode amplitude shall be maintained at one twenty-fifth of the active span length for the duration of the test. Reasonable movements at both dead end and at the suspension are permitted in order to promote steady galloping motions in the active span. The galloping amplitude in the passive span shall not exceed the amplitude in the active span.

### **Acceptance criteria**

- a) Any cracking or breaking of any component of the OPGW cable or the supporting hardware shall constitute failure. This assessment is made with the naked eye.
- b) A permanent or temporary increase in optical attenuation greater than 0.2 dB/test fiber km at nominally 1550 nm for single-mode fibers shall constitute failure.

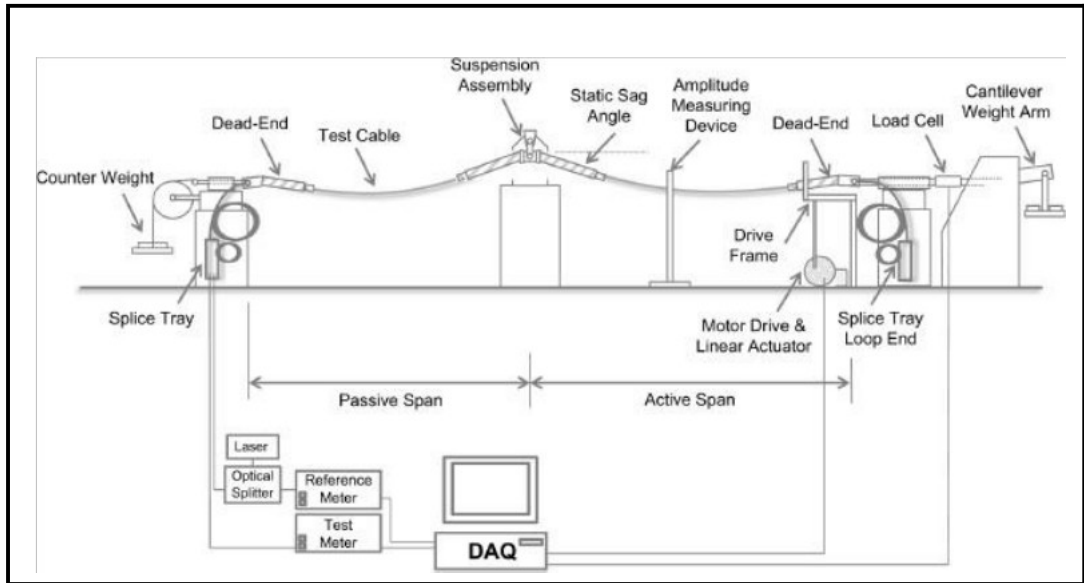

Figure 5.1: General Arrangement for Galloping Test

**OBSERVATIONS, IF ANY:**

**TEST RESULT:** The OPGW cable met/not met the acceptance criteria for Galloping test.

**(TESTED BY)**

Sign & Date

**(WITNESSED BY)**

Sign & Date

**TYPE TEST PROCEDURE FOR OPGW CABLE****(6) Test Name: Cable Bend Test****Final Customer: Power Grid Corporation of India Limited, India.****Project Name:****Manufacturer:****Cable Type:****Standard: IEEE1138-2021 Method 6.5.2.3****Classification:** Installation/mechanical/mandatory**Intent**

The intent of the Bend Test is to subject the OPGW cable to a bending action similar to what might be experienced during installation. The cable and/or the fiber unit(s) could be damaged, and the optical performance could be adversely affected.

**Objective**

- a) To verify the mechanical integrity of the OPGW cable when subjected to the specified minimum bend radius.
- b) To verify the optical performance of the OPGW cable when subjected to the specified minimum bend radius.

**Set-up**

The preparation of the fibers and number of fibers to be spliced shall be according to 6.2.

**Procedure**

The minimum bend radius specified by the manufacturer shall be used for the maximum bend radius of the test set-up unless a larger value is agreed to between supplier and purchaser.

The cable sample shall be wrapped two complete times in a close helix around a mandrel with a radius no larger than the minimum bend radius specified by the manufacturer. Sufficient tension shall be applied to keep the sample in close contact to the mandrel. The cable shall be held in this position for 1 min.

A reference optical measurement shall be taken prior to bending. Another measurement shall be made after the cable is bent around the mandrel and held stationary. The difference between the two signals for the initial optical measurement provides the test result. The change in this difference during the test would indicate any changes of attenuation in the test fiber. The signals shall be recorded using a digital data logging system.

**Acceptance criteria**

a) There shall be no cracking or breaking of any component of the OPGW cable constitutes failure.

This assessment is made with the naked eye.

b) There shall be no permanent increase in optical attenuation greater than 0.05 dB/fiber at 1550 nm $\pm$  20 nm for single-mode fibers.

**OBSERVATIONS, IF ANY:**

**TEST RESULT:** The OPGW cable met/not met the acceptance criteria for Cable Bend test.

**(TESTED BY)**

Sign &amp; Date

**(WITNESSED BY)**

Sign &amp; Date

**TYPE TEST PROCEDURE FOR OPGW CABLE****(7) Test Name: Sheave Test****Final Customer: Power Grid Corporation of India Limited, India.****Project Name:****Manufacturer:****Cable Type:****Standard: IEEE 1138-2021 Method 6.5.2.1****Classification:** Installation/mechanical/mandatory**Intent**

The intent of the Sheave Test is to subject the OPGW cable to a simulated action of being pulled over a number of sheaves during installation. Installation includes stringing and sagging operations. During installation, it is possible the OPGW cable could become excessively deformed. The optical unit(s) could also be damaged, and the optic fibers adversely affected.

**Objective**

- a) To verify the mechanical integrity of the OPGW cable when subjected to the specified installation conditions.
- b) To verify the optical performance of the OPGW cable when subjected to the specified installation conditions.

**Set-up**

The general arrangement for the Sheave Test is shown in Figure 7.1. For optical attenuation measurements, the cable shall be prepared according to 6.3. The length of OPGW cable between loading points of the dead-end assemblies shall be a minimum of 8 m. The sheave shall be rigidly supported such that it cannot swing. For the sheave test, the nominal diameter of the sheave shall be 40 times the OPGW cable diameter unless otherwise specified. For practical reasons, considering commercially available sheave sizes, the chosen sheave shall be between 38 times and 42 times the OPGW cable diameter unless otherwise specified by the cable manufacturer.

NOTE—For installation applications, refer to IEEE Std 524 for the minimum sheave diameter and block recommendations, unless otherwise specified by the manufacturer. The sheave may be grooved or ungrooved and lined. The cable is initially tensioned to  $15\% \pm 1\%$  of the cable UTS at a total deflection angle of  $30^\circ \pm 2^\circ$  over the sheave. The method of attachment, while not required to be rigid, is limited to the twisting of the cable occurring near the dead ends. A suitable instrument, such as a dynamometer or load cell, is installed to measure the tension in the OPGW cable during

the test.

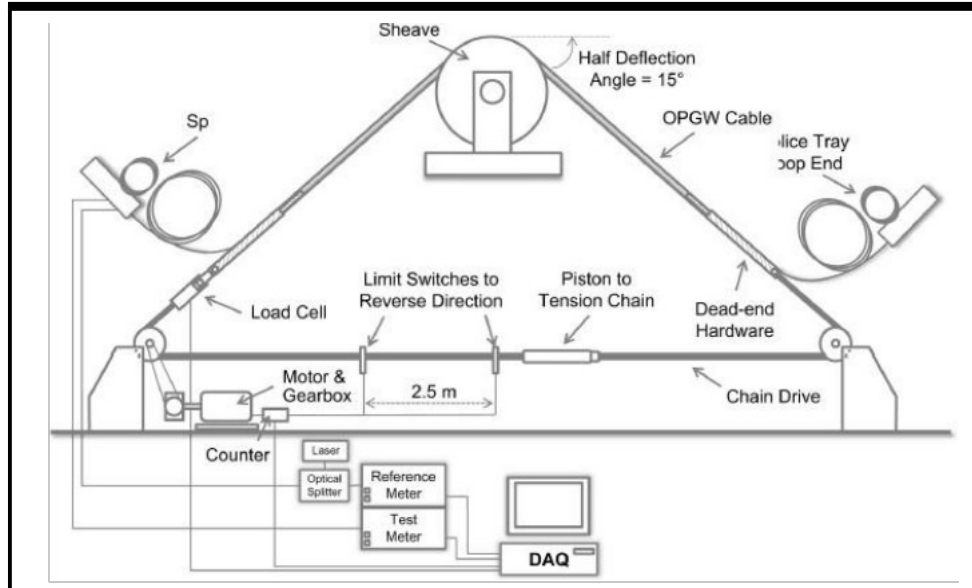

Figure 7.1—General test arrangement for sheave

### Procedure

At least 2.5 m of the cable sample shall be pulled 20 cycles (i.e., 20 times in each direction) over the sheave.

Before the first pull, the midpoint and both ends of the 2.5 m length shall be located and marked. A suitable instrument (e.g., caliper, micrometer) shall be used to measure the maximum and minimum diameters at the three locations after tensioning before the first cycle and after the twentieth cycle. If necessary, the cable tension may be adjusted between cycles to maintain the level at 15% ± 1% UTS before each cycle.

The cable tension and the optical power meter signals shall be recorded at least two times every cycle using a suitable data logging system.

After the test, the cable section passing over the sheave shall be dissected and all cable components visually examined for any damage. The maximum and minimum diameters ( $d_{max}$  and  $d_{min}$ , respectively) of the unit(s) containing the fibers shall be measured at the same locations as the cable diameters were measured.

The ovality of the cable and of the metallic unit containing the fibers shall be calculated after the test using the following calculation:

$$\text{Ovality} = ((d_{max} - d_{min}) / (d_{max} + d_{min})) * 100\% \quad (1)$$

**Acceptance criteria**

- a) The ovality of the cable and metallic units at the measured locations shall not exceed 10%.
- b) Cracking or breaking of any component of the OPGW cable caused by the test shall constitute failure. This assessment is made with the naked eye.
- c) A permanent increase in optical attenuation greater than 0.1 dB/test fiber km at  $1550 \text{ nm} \pm 20 \text{ nm}$  for single-mode fibers shall constitute failure.

**OBSERVATIONS, IF ANY:**

**TEST RESULT:** The OPGW cable met/not met the acceptance criteria for Sheave test.

**(TESTED BY)**

Sign &amp; Date

**(WITNESSED BY)**

Sign &amp; Date

**TYPE TEST PROCEDURE FOR OPGW CABLE****(8) Test Name: Crush Test****Final Customer: Power Grid Corporation of India Limited, India.****Project Name:****Manufacturer:****Cable Type:****Standard: IEEE 1138-2021 Method 6.5.2.2****Classification:** Installation/mechanical/conditional**Intent**

The intent of the Crush Test is to subject the OPGW cable to simulated crushing or clamping forces that could occur during installation or maintenance. The cable could be crushed to the extent of adversely affecting the optical signals or reducing the tensile strength.

**Objective**

- a) To verify the mechanical integrity of the OPGW cable and the supporting hardware when subjected to crush forces. Reference IEEE Std 1591.1.
- b) To verify the optical performance of the OPGW cable when subjected to crush forces.

**Set-up**

The set-up for the Crush Test is shown in Figure 8.1. An untested cable section from the test sample prepared for the Sheave Test may be used for the Crush Test.

The number of fibers to be spliced shall be according to 6.3.

The cable shall be supported between two steel plates that transfer a compressive load uniformly over a 100 mm length of the sample. The edges of the plates shall be slightly rounded. The cable and plates shall be positioned in a suitable test machine. The test shall be carried out in a temperature-controlled laboratory at  $22\text{ }^{\circ}\text{C} \pm 3\text{ }^{\circ}\text{C}$ .

The crush load and the optical power meters shall be monitored and recorded every second by a digital data logging system.

**Procedure**

The test shall be performed in accordance with the most recent revision of EIA/TIA-455-41.

The cable shall be mounted between the plates with minimal load such that the cable is firmly positioned along the length of the steel plates. The load shall be then gradually increased to the value specified by the supplier within 1 min and 2 min and held for 10 min. The test shall be performed at three locations approximately 1 m apart.

The ovality of the cable and of the metallic unit(s) containing the fibers shall be calculated after the test using the following calculation:

$$\text{Ovality} = ((d_{\text{max}} - d_{\text{min}}) / (d_{\text{max}} + d_{\text{min}})) * 100\%$$

### Acceptance criteria

- a) Any ovality of the cable or optical fiber units at the measured locations that exceed 10% shall constitute failure.
- b) Any cracking or breaking of any component of the OPGW cable shall constitute failure.

This assessment is made with the naked eye.

- c) A permanent increase in optical attenuation greater than 0.05 dB/fiber at  $1550 \text{ nm} \pm 20 \text{ nm}$  for single-mode fibers shall constitute failure.

The above criteria shall apply to all three test locations.

**Figure 8.1: General Arrangement for Crush Test**

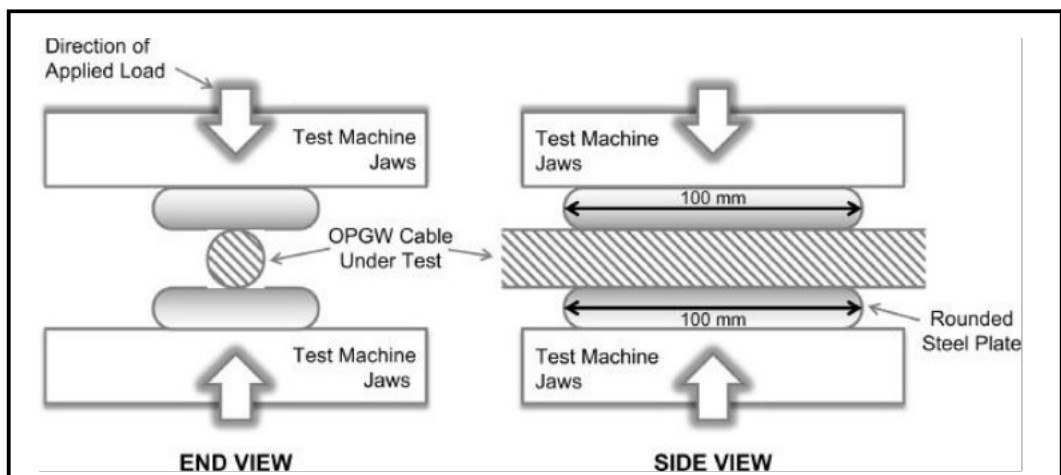

**OBSERVATIONS, IF ANY:**

**TEST RESULT:** The OPGW cable met/not met the acceptance criteria for Crush test.

**(TESTED BY)**

Sign & Date

**(WITNESSED BY)**

Sign & Date

**TYPE TEST PROCEDURE FOR OPGW CABLE****(9) Test Name: Twist Test****Final Customer: Power Grid Corporation of India Limited, India.****Project Name:****Manufacturer:****Cable Type:****Standard: IEEE 1138-2021 Method 6.5.2.4****Classification:** Installation/mechanical/mandatory**Intent**

The intent of the Twist Test is to subject the OPGW cable to a simulated action of being pulled during installation (i.e., stringing and sagging). During installation, the OPGW cable could become excessively deformed. The optical unit(s) could also be damaged, and the optical performance could be adversely affected.

**Objective**

- a) To verify the mechanical integrity of the OPGW cable when subjected to the specified installation conditions.
- b) To verify the optical performance of the OPGW cable when subjected to the specified installation conditions.

**Set-up**

The general arrangement for the twist test is shown in Figure 9.1. An OPGW cable sample shall be installed in a suitable tension test machine. The length of the cable between the dead-end assemblies shall be at least 10 m. One dead-end assembly shall be attached to the tensioning device through a load cell. The other dead-end assembly shall be attached to the stationery end of the test machine through a swivel. The OPGW cable sample shall be fixed onto itself so as to allow rotational motion without disturbing the optical splice arrangement.

The OPGW cable sample shall be terminated beyond both dead-end assemblies such that the optical fibers could not move relative to the OPGW cable. The cable and fiber terminations and the method to measure optical attenuation are described in 6.3.

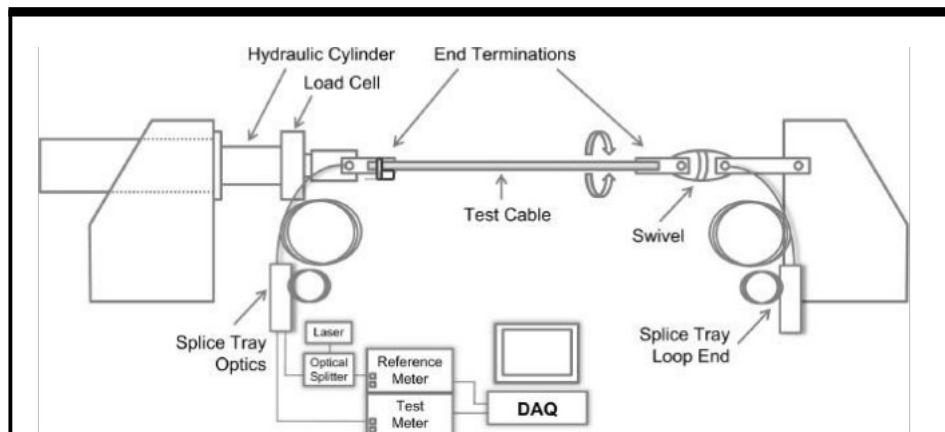

**Figure 7—General arrangement for twist test**

### Procedure

The cable shall be tensioned to 20% of the cable UTS. The cable sample shall be rotated in the direction of the lay of the strands for two and one-half turns (i.e., “tightening” the lay of the cable). This number of turns shall be calculated from the test cable length to produce a total twist in the cable of 90° per meter. The cable sample shall be rotated back to the initial position. The cable shall be rotated in the reverse direction to the lay of the strands (i.e., “loosening” the lay of the cable). The cable sample shall be again reversed in direction to rotate the cable sample to its original position. This constitutes one torsion cycle. This cycle shall be repeated a second time. The signals from the optical power meters and the cable tension as measured by the load cell shall be monitored continuously using a data logging system.

### Acceptance criteria

- a) Any cracking or breaking of any component of the OPGW cable shall constitute failure. This assessment is made with the naked eye.
- b) A permanent increase in optical attenuation greater than 0.10 dB/test fiber km at 1550 nm  $\pm$  20 nm for single-mode fibers shall constitute failure.



**OBSERVATIONS, IF ANY:**

**TEST RESULT:** The OPGW cable met/not met the acceptance criteria for Twist test.

**(TESTED BY)**

Sign & Date

**(WITNESSED BY)**

Sign & Date

**TYPE TEST PROCEDURE FOR OPGW CABLE****(10) Test Name: Creep Test****Final Customer: Power Grid Corporation of India Limited, India.****Project Name:****Manufacturer:****Cable Type:****Standard: IEEE 1138-2021 Method 6.5.1.1****Classification :** Cable characteristic/mechanical/conditional**Intent**

The intent of the Creep Test is to determine the long-term tensile creep characteristics of the OPGW cable. This information is used in the sag-tension calculations during the design layout of an optical fiber cable system.

**Objective**

- a) To produce the long-term, room temperature tensile creep curve and equation for the OPGW cable.
- b) The optical performance of the OPGW cable is not required to be monitored during this test unless specified by the cable purchaser.

**Set-up**

The general arrangement for the creep test is shown in Figure 10.1.

The test shall be set up in accordance with IEC 61395 [B2] unless otherwise specified by the cable purchaser and were noted in this standard.

The OPGW cable sample shall be terminated such that all the load carrying components of the cable are prevented from moving relative to each other at the loading points. A suggested method is to use epoxy resin grips to encapsulate all components of the cable at the loading points.

The OPGW cable sample shall be installed in a test facility suitable for creep testing. The length of the cable between the loading points of the dead-end assemblies shall be ~10 m. The cable shall be preloaded to a maximum of 2% of the UTS of the cable. The cable shall not remain at the preload value for more than 5 min. A suitable transducer shall be used to measure the longitudinal cable elongation over a gauge length of ~8 m. A suitable transducer such as a load cell or dynamometer shall be used to measure the tension in the cable.

A shorter cable length or gauge length may be used, provided that the accuracy of the strain measuring device satisfies the guidelines outlined in IEC 61395.

The cable temperature shall be measured at both ends of the gauge section. The test shall be carried out in a temperature-controlled environment at  $22\text{ }^{\circ}\text{C} \pm 3\text{ }^{\circ}\text{C}$ .

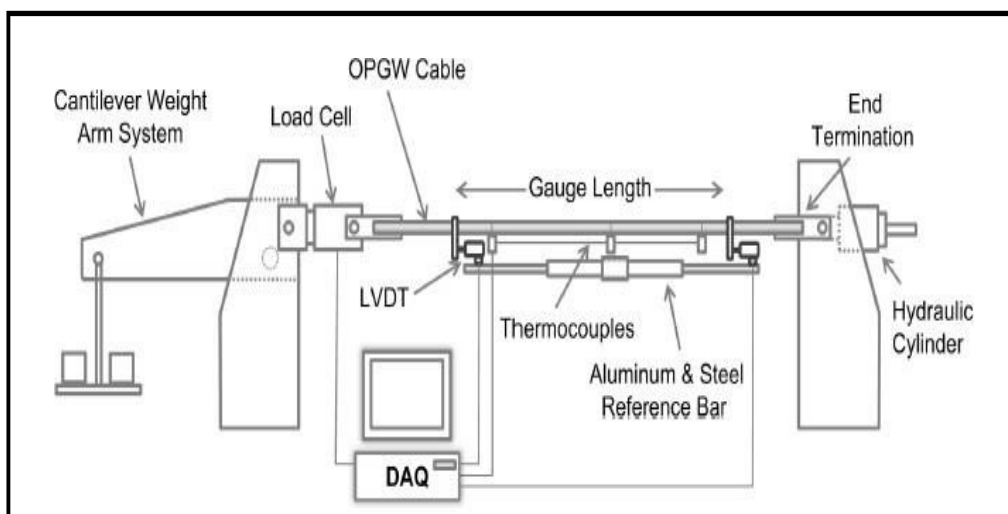

**Figure 10.1-General arrangement for creep test**

### Procedure

The test shall be performed in accordance with IEC 61395 unless otherwise specified by the cable purchaser or noted in this standard.

The test shall comprise of the two separate tensions of 25% and 40% of the UTS of the cable unless otherwise specified by the cable purchaser and depending on laboratory capability.

The cable shall be tensioned at a rate such that the time to reach the test tension  $\pm 2\%$  of this tension is  $5\text{ min} \pm 10\text{ s}$ . Final adjustments may be made to achieve the test tension within 10 min of the start of loading. However, the load shall remain within  $\pm 2\%$  of the test tension at all times while any final adjustments are made. Sudden loading or unloading of the cable shall be avoided at all times. For each tension, the load on the cable shall be maintained at the test tension  $\pm 1\%$  for 500 h.

The elongation of the cable and applied load shall be monitored and recorded during the test as per IEC 61395 using a suitable data logging system.

**Acceptance criteria**

Unless otherwise specified by the cable purchaser, there are no acceptance criteria for this test.

**OBSERVATIONS, IF ANY:**

**TEST RESULT:** The OPGW cable met/not met the acceptance criteria for creep test.

**(TESTED BY)**

Sign & Date

**(WITNESSED BY)**

Sign & Date

**TYPE TEST PROCEDURE FOR OPGW CABLE****(11) Test Name: MRDT (Strain Margin Test) Test****Final Customer: Power Grid Corporation of India Limited, India.****Project Name:****Manufacturer:****Cable Type:****Standard: IEEE 1138-2021 Method 6.5.1.3****Classification:** Cable characteristic/mechanical/mandatory**Intent**

The intent of the MRDT test is to tension the cable up to the manufacturer's MRDT and observe the fiber strain and verify that acceptable optical performance is maintained.

NOTE—The MRDT is a load limit that the manufacturer recommends not be exceeded should the cable be exposed to its heavy load conditions.

**Objective**

- a) To determine the cable tension at which the optical fibers begin to strain (0.05% strain level).
- b) To verify the optical performance of the OPGW cable during the test up to the MRDT.

**Set-up**

The OPGW cable sample shall be terminated such that all of the load carrying components of the cable are prevented from moving relative to each other at the loading points. For optical attenuation measurements, the cable shall be prepared according to 6.3. The number of fibers to be spliced shall be according to 6.3 less the number used for fiber elongation.

For the fiber elongation measurement, at least four fibers shall be spliced together. Fiber elongation shall be measured using suitable optical equipment. If the optical equipment is able to measure fiber strain directly, then a gauge length is not required. If the equipment used measures absolute fiber elongation, such as a high resolution OTDR, then the gauge length shall be taken to be the length of fiber from dead end to dead end, plus half the length of each set of three loops beyond each dead end.

The OPGW cable sample shall be installed in a suitable tensile test machine. The length of the cable between the loading points of the dead-end assemblies shall be a minimum of 10 m. The cable shall be preloaded to a maximum of 2% of the UTS of the cable. It shall be supported over its length such

that the cable will not lift by more than 10 mm at the test tension condition. A suitable transducer shall be used to measure the longitudinal cable elongation over a gauge length of at least 8 m. A suitable transducer such as a load cell or dynamometer shall be used to measure the tension in the cable.

The test shall be carried out in a temperature-controlled environment at  $22\text{ }^{\circ}\text{C} \pm 3\text{ }^{\circ}\text{C}$ .

**Procedure**

The cable shall be tensioned to the manufacturer’s MRDT at a uniform rate that is used to achieve the cable UTS in 20 min to 30 min. The load shall be held for 5 min at the MRDT. Readings of the optical attenuation, fiber, and cable elongation shall be taken at periodic intervals, at least every 5 min while loading the cable.

The load shall be reduced back to 2% UTS and permanent attenuation measured.

If fiber elongation was not reached during the first cycle, the load may be continuously increased up to 100% UTS or until the fibers begin to elongate. The data from the instruments shall be recorded simultaneously. This step is considered for information only. Refer to Fig. 11.1 for loading schedule for MRDT test.

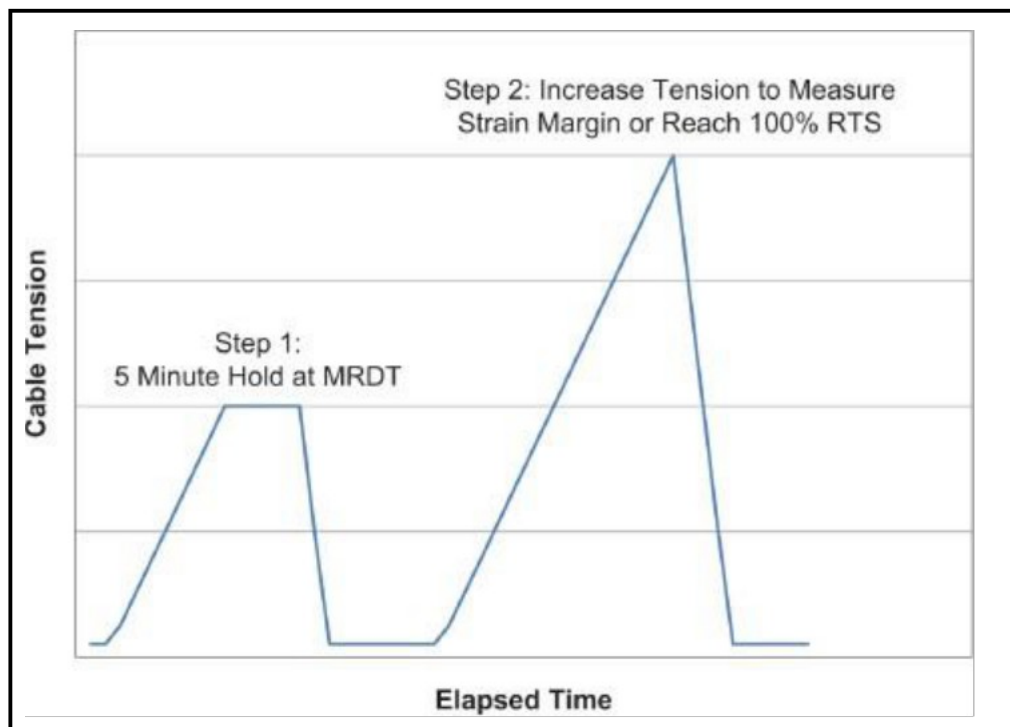

**Figure 11.1—Loading schedule for MRDT test**

The strain margin is assumed to be the cable strain (or cable load) at which the fibers are measurably strained in the context of sample preparation and resolution of measuring equipment (typically equal or greater than 0.05%).

From the strain margin point, it is expected that the slope of the cable strain and fiber strain should be parallel when plotted.

NOTE-If agreed between the supplier and the purchaser, the cable may be loaded to failure on completion of the MRDT test to obtain the breaking strength of the cable. If this is done, it is not considered part of the MRDT test and therefore cable strain measurements are not required. If a breaking strength test is performed, the load is to be applied at a rate such that the time to reach the UTS of the cable is at least 5 min. Premature failure of the cable during the breaking strength test does not invalidate the data obtained from the MRDT test.

### Acceptance criteria

The cable shall show no permanent change in attenuation per test fiber km from preload to the maximum rated design tension (MRDT) of the cable at  $1550 \text{ nm} \pm 20 \text{ nm}$  for single-mode fibers.

### OBSERVATIONS, IF ANY:

**TEST RESULT:** The OPGW cable met/not met the acceptance criteria for MRDT test.

**(TESTED BY)**

Sign & Date

**(WITNESSED BY)**

Sign & Date

**TYPE TEST PROCEDURE FOR OPGW CABLE****(12) Test Name: Stress Strain Test****Final Customer: Power Grid Corporation of India Limited, India.****Project Name:****Manufacturer:****Cable Type:****Standard: IEEE 1138-2021 Method 6.5.1.2****Classification :** Cable characteristic/mechanical/mandatory**Intent**

The intent of the stress-strain test is to determine the stress-strain characteristics and the final modulus of elasticity (MOE) of the OPGW cable. This information is used in the sag-tension calculations during the design layout of an overhead cable system.

**Objective**

- a) To produce the stress-strain curve and the initial and final MOEs for the OPGW cable.
- b) Monitoring the optical performance of the OPGW cable is not required during this test unless specified by the cable purchaser.

**Set-up**

The general arrangement for the stress-strain test is shown in fig.12.1. The test shall be set up in accordance with IEC 61089[B1] unless otherwise specified by the cable purchaser and where noted in this standard.

The OPGW cable sample shall be terminated such that all the load carrying components of the cable are prevented from moving relative to each other at the loading points. A suggested method is to use epoxy-resin grips to encapsulate all components of the cable.

The OPGW cable sample shall be installed in a suitable tensile test machine. The length of the cable between the loading points of the dead-end fittings shall be a minimum of 10 m. The cable shall be preloaded to a maximum of 2% of the UTS of the cable. It shall be supported over its length such that the cable will not lift by more than 10 mm at the maximum tension condition. A suitable transducer shall be used to measure the longitudinal cable elongation over a gauge length of at least 8 m. A suitable transducer, such as a load cell or dynamometer, shall be used to measure the tension in the cable.

The test shall be carried out in a temperature-controlled environment at  $22\text{ }^{\circ}\text{C} \pm 3\text{ }^{\circ}\text{C}$ .

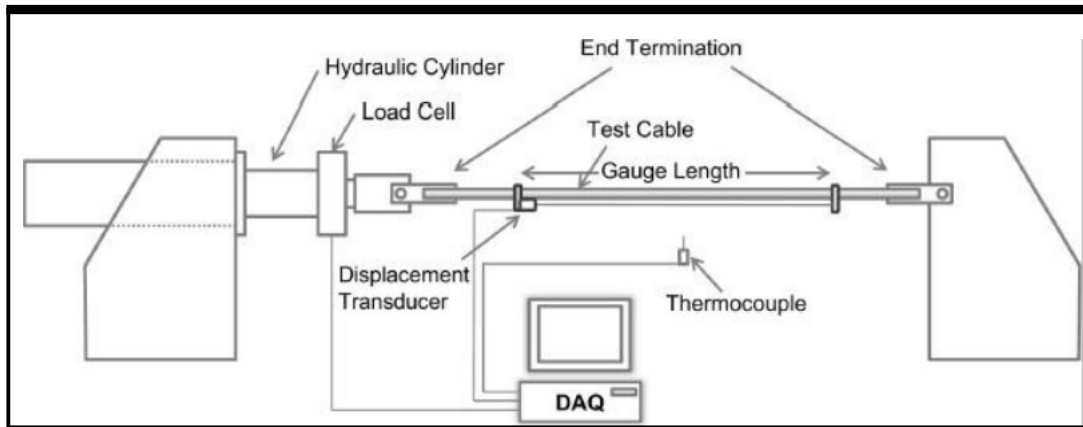

Figure 12.1-General arrangement for stress-strain test

**Procedure**

The test shall be performed in accordance with IEC 61089 unless otherwise specified by the cable purchaser or noted in this standard.

The cable shall be tensioned according to the loading schedule in the following table. To reduce creep during loading, all loads shall be applied based on the rate to reach 30% of UTS within one to two minutes. Higher rates may be used, if agreed between the supplier and the purchaser. The elongation of the cable and applied load shall be monitored and recorded at appropriate intervals using a suitable data logging system. Load and elongation data shall be recorded a minimum of every 5 min during each hold period and at all preloads. If possible, more frequent readings are preferred.

See Table 2.

**Table 2 —Tension loading schedule**

Step	Load UTS %	Hold time (min)
Preload	2	—
1	30	30
Preload	2	< 2
2	50	60
Preload	2	< 2
3	70	60
Preload	2	< 2
4	85	60
Preload	2	—

The slope of the final unloading curve from 85% UTS is the final MOE of the cable.

If agreed between the supplier and the purchaser, the cable may be loaded to failure on completion of the Stress-Strain Test to obtain the breaking strength of the cable. If this is done, it is not considered part of the Stress-Strain Test and therefore cable strain measurements are not required. If a breaking strength test is performed, the load shall be applied at a rate such that the time to reach the UTS of the cable is at least 5 min. Premature failure of the cable during the breaking strength test does not invalidate the data obtained from the Stress-Strain Test.

### Acceptance criteria

Unless otherwise specified by the cable purchaser, there are no acceptance criteria for the Stress-Strain Test.

If performed the breaking strength of cable shall meet or exceed 100% of the cable UTS.

### OBSERVATIONS, IF ANY:

**TEST RESULT:** The OPGW cable met the acceptance criteria for Stress Strain test.

**(TESTED BY)**

Sign & Date

**(WITNESSED BY)**

Sign & Date

## TYPE TEST PROCEDURE FOR OPGW CABLE

**(13) Test Name: Temperature Cycling Test**

**Final Customer: Power Grid Corporation of India Limited, India.**

**Project Name:**

**Manufacturer:**

**Cable Type:**

**Standard: IEEE 1138-2021 Method 6.5.3.7**

**Classification:** In-service/environmental/mandatory

### **Intent**

To subject the OPGW cable to extreme temperatures as may be experienced in the field by the cable.

### **Objective**

To verify the optical performance of the OPGW cable when subjected to the specified temperature conditions.

### **Set-up**

A sample with a minimum of 500 m of cable shall be placed in a suitable thermal chamber.

For optical attenuation measurements, the optical cable sample shall be prepared according to 6.3.

Two thermocouples shall be placed in the environmental chamber to measure the temperature.

They shall be placed on a 25 cm cable sample located either side of the cable reel.

### **Procedure**

The test shall be performed in accordance with the most recent revision of TIA/EIA-455-3.

The cable shall be subjected to two thermal cycles. A thermal cycle is based on the chamber temperature starting at  $22\text{ }^{\circ}\text{C} \pm 3\text{ }^{\circ}\text{C}$ , lowering to at least  $-40\text{ }^{\circ}\text{C}$  and holding for a minimum of 16 h. The temperature shall then be increased to at least  $85\text{ }^{\circ}\text{C}$  and held for a minimum of 16 h. To complete the cycle, the temperature shall be returned to  $22\text{ }^{\circ}\text{C}$ . All temperature transitions shall be conducted at a rate of  $20\text{ }^{\circ}\text{C}$  to  $40\text{ }^{\circ}\text{C}$  per hour. The chamber temperature is based on the average of the two thermocouples on the 25 cm cable samples.

At a minimum, the thermocouples and optical data shall be recorded at the beginning and end of the test and at the beginning and end of every hold period.

Refer to Figure 13.1 for a typical example of a temperature profile for a temperature cycling test.

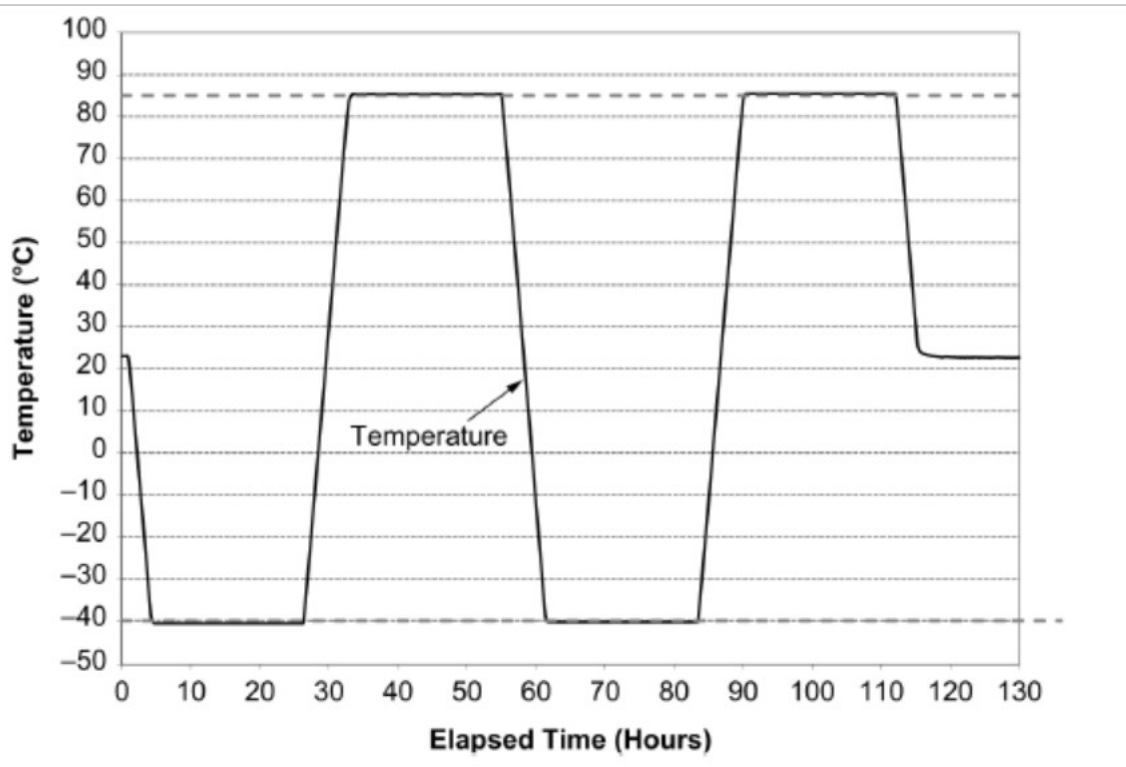

Figure 13.1-Typical temperature profile for temperature cycling test

**Acceptance criteria**

A permanent or temporary increase in optical attenuation greater than 0.2 dB/test fiber km at 1550 nm ± 20 nm for single-mode fibers shall constitute failure.

**OBSERVATIONS, IF ANY:**

**TEST RESULT:** The OPGW cable met/not met the acceptance criteria for Temperature Cycling test.

**(TESTED BY)**

Sign & Date

**(WITNESSED BY)**

Sign & Date

**TYPE TEST PROCEDURE FOR OPGW CABLE**

**(14) Test Name: Corrosion (Salt Spray Test)**

**Final Customer: Power Grid Corporation of India Limited, India.**

**Project Name:**

**Manufacturer:**

**Cable Type:**

**Standard: IEEE 1138-2021 Method 6.5.3.8**

**Classification:** Storage/in-service, environmental/conditional

**Intent**

To subject the OPGW cable to salt fog corrosion that may be experienced in the field by the cable.

**Objective**

The objective of this test is to determine the effects of a controlled salt atmosphere on the OPGW sample.

**Set-up**

This test is a 1000 h saltbox spray test. Three cable samples of  $75 \text{ cm} \pm 5 \text{ cm}$  shall be cut from the reel of OPGW. Heat shrink tubing or silicone seal shall be placed over both ends of the cable to a distance not to exceed  $7.5 \text{ cm} \pm 0.5 \text{ cm}$  from either end of the cable sample. The purpose of the tubing is to reduce or eliminate the corrosion occurring at the open ends of the test cable.

**Procedure**

Pre-test cleaning and handling:

- = During cutting and preparation of the test samples, care shall be taken not to introduce any contamination or debris onto the surface of the cable samples.
- = Samples shall not be disassembled or rinsed.
- = Optionally, samples may be cleaned using forced air supply to remove any foreign particles from the surface. This may not be applicable for greased cable designs.

The test cables are placed into a standard salt spray-testing box as defined by ISO 9227 [B7] or ASTM B 117 [B1]. The cable samples are to be placed horizontal in the test chamber to simulate a standard horizontally suspended OPGW cable. The test is to run continuously for 1000 h for salt spray testing.

Post-test cleaning and handling:

- = Unless otherwise specified, the cable samples shall be carefully removed from the chamber, with care not to damage or disturb the tested samples.
- = As specified in ASTM B117, samples may be gently washed or dipped in clean running water not warmer than 38 °C (100 °F) to remove salt deposits from the surface, and then immediately dried.

Visual inspection:

- a) Samples shall be inspected as soon as possible once removed from the chamber.
- b) Samples shall be inspected with the unaided eye. A low magnification lens may be used for the suspect areas.
- c) Samples with heavier salt deposits may be lightly brushed to remove the surface deposits. Care shall be taken not to disturb the underlying metallic surface.
- d) In the event suspect locations are found in more than two locations, additional detailed inspections may be warranted under higher magnification. 1) For example: If wires are identified on all three samples, where the aluminum cladding appears to have corroded to expose the underlying steel member, a suitable metallographic analysis [e.g., potted cross section or energy dispersive spectroscopy (EDS)] may be used.
- e) Samples sent for additional detailed inspection shall not be disturbed any way (i.e., no brushing).

### **Acceptance criteria**

At the end of the test, the cables are to be removed and dissected for corrosion damage. The cable design has failed and is not suitable for high corrosion sites if:

- a) There is more than one location (see NOTE) where the aluminum-clad steel wires have been pitted so as to expose the underlying steel strength member in any way whatsoever.

- b) There is more than one location (see NOTE) where solid aluminum wires have been point pitted beyond a depth of 10% of the total individual wires diameter at the point of the pit.
- c) There is damage to the optical fiber unit (e.g. material loss, point pitting beyond a depth of 10% of the tube thickness, deformation of the tube or any other condition that may affect the performance of the fibers).
- d) In the case of aluminum coated tubing, there can be no removal of the aluminum coating that exposes the underlying stainless-steel tube.
- e) In the case of “other” coated tubing or wires, there can be no removal of the coating that exposes the underlying tubing to the elements.

NOTE—One (1) suspect location, in only one (1) wire, may not be a significant representation of the overall cable performance.

**OBSERVATIONS, IF ANY:**

**TEST RESULT:** The OPGW cable met/not met the acceptance criteria for Corrosion (Salt Spray test).

**(TESTED BY)**

Sign & Date

**(WITNESSED BY)**

Sign & Date

**TYPE TEST PROCEDURE FOR OPGW CABLE**

**(15) Test Name: Ultimate Tensile Strength Test**

**Final Customer: Power Grid Corporation of India Limited, India.**

**Project Name:**

**Manufacturer:**

**Cable Type:**

**Standard: IEEE 1138-2021 Method 6.5.1.4**

**Classification:** Cable characteristic/mechanical/mandatory

**Intent**

The intent of the Ultimate Tensile Strength Test is to determine the actual measured breaking strength of the cable.

**Objective**

- a) To verify that the actual (ultimate) tensile strength of the OPGW cable meets or exceeds the UTS of the OPGW cable specified by the supplier.
- b) Monitoring the optical performance of the OPGW cable is not required during this test unless specified by the cable purchaser.

**Set-up**

The OPGW cable sample shall be installed in a suitable tensile test machine. The length of the cable between the loading points of the dead-end assemblies shall be a minimum of 10 m. A suitable transducer such as a load cell or dynamometer shall be used to measure the tension in the cable.

**Procedure**

The load shall be applied at a uniform rate to reach the UTS of the cable in at least 5 min. The ultimate tensile strength of the cable shall be defined as the maximum measured load of the cable at failure. Individual strand failures above UTS do not necessarily constitute an ultimate cable failure. However, there shall be no mechanical failures in the cable below 100% UTS. This is to reduce the chances that the outer strands will unravel below the maximum design loading conditions.

This test may be performed separately or on the same cable sample as the stress-strain test or the MRDT Test. In this case, the ultimate tensile strength test would be performed immediately following the stress-strain test or the strain margin test.

**Acceptance criteria**

The ultimate tensile strength (UTS) of the OPGW cable shall meet or exceed 100% of the UTS of the cable. In addition, there shall be no outer layer strand failure in the cable below 100% UTS.

However, if the maximum load does not meet 100% of the UTS of the cable, and if either of the following

occurs the test shall be repeated with an alternative gripping mechanism:

Apr 26, Revision-02

- a) The break occurs inside or within 50 mm (2 in) of a dead-end fitting.
- b) The OPGW cable slips in a dead-end fitting.

NOTE—If this is a systems test, the above exceptions would not apply.

**OBSERVATIONS, IF ANY:**

**TEST RESULT:** The OPGW cable met/not met the acceptance criteria for Ultimate Tensile Strength Test .

**(TESTED BY)**

Sign & Date

**(WITNESSED BY)**

Sign & Date

## TYPE TEST PROCEDURE FOR OPGW CABLE

**(16) Test Name: Lightning Arc Test**

**Final Customer: Power Grid Corporation of India Limited, India.**

**Project Name:**

**Manufacturer:**

**Cable Type:**

**Standard: IEEE 1138- 2021 Method 6.5.3.4**

**Classification:** In-service/electrical, mechanical, environmental/mandatory

### Intent

The intent of the lightning arc test is to subject the OPGW cable to an electrical arc that is intended to simulate the damaging portion of the lightning arc strike that represents possible field condition.

### Objective

- a) To verify the mechanical performance of the OPGW cable when subjected to the simulated lightning conditions for the specified class as per table 5.
- b) To verify the optical performance of the OPGW cable when subjected to the simulated lightning conditions for the specified class as per Table 5.

### Set-up

The general arrangement for the lightning arc test is shown in Fig 16.1, unless otherwise specified by the cable purchaser.

### Test apparatus

The sample shall be of sufficient length to perform up to six simulated lightning arc strikes in six separate sections followed by tension tests. The location of the lightning arc strike shall be applied in the center of each section. Each section of the OPGW sample shall be installed between two fixed abutments. The length of the cable section between the load points of the dead-end assembly shall be greater than 10 m.

A suitable instrument, such as load cell or dynamometer shall measure the tension in the cable.

The OPGW shall be grounded. Suitable equipment to apply the specified simulated arc shall be used to generate a dc current compatible with the values in Table 5.

An electrode with a plane surface shall be used to apply the simulated lightning arc. The electrode should be a material that is not damaged by repeated arcs, such as tungsten. The location of the electrode and returning current points should be symmetrical to balance the electromagnetic forces and stabilize the current arc applied to the cable. A thin filament may be used to initiate the simulated lightning arc strike to the cable. The intent of the filament is to initiate the arc so it should be of minimum diameter and conductivity to maximize the current transfer on the cable. The current waveform shall be measured versus time with a suitable device capable of sampling to at least 1000 Hz. The charge transference shall be calculated from the current trace (area under the curve).

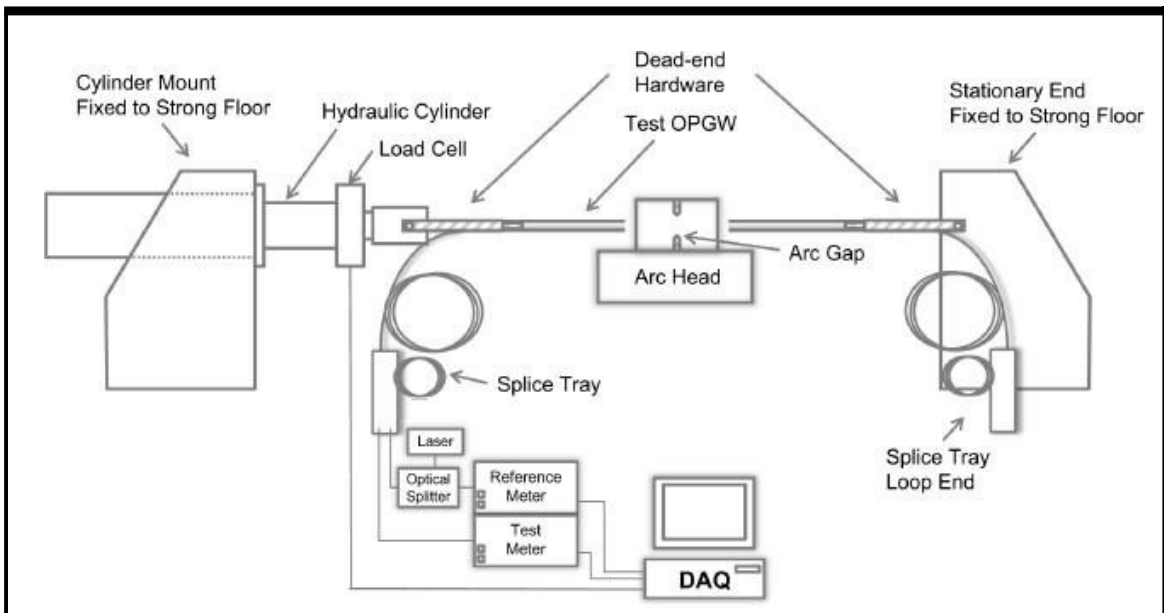

**Figure 11—General arrangement for lightning arc test**

**Optical network**

For optical attenuation measurements, the sample shall be prepared according to 6.3. The optical attenuation shall be monitored during each simulated lighting arc strike and recorded by a digital data logging system at a suitable sampling rate. The tension may be recorded manually. Optical attenuation measurement are not required during the tension tests.

**Procedure**

The cable sample shall be tested to a class rating according to Table 5. Simulated lighting strikes shall be applied in up to six separate locations in the center of each section. To validate the class rating, the cable shall withstand the respectively charge transfer in Table 5. The test class of the OPGW cable shall be specified by the purchaser or manufacturer.

**Table 5—Charge transfer class rating Arc exposure:**

	Class 0	Class 1	Class 2	Class 3
Current (A)	100	200	300	400
Duration (s)	0.5	0.5	0.5	0.5
Charge transfer ( $C = A \times s$ )	50	100	150	200

Each of the cable sections shall be tensioned to 15% to 20% of the cable UTS at a temperature of 22°C ±3 °C. An arc current with negative polarity on the electrode shall be applied to the cable through a 5 cm ±1 cm long thin filament. The charge transference to the cable shall be as specified by the purchaser or manufacturer. The tolerance on the charge transference for each individual strike is ±10%. A charge exceeding 110% of the target value may also be acceptable, if agreed between the purchaser and manufacturer. A total of five sections shall be successfully exposed to the specified charge transference, with the average of the five charge transfers to exceed 95% of the target. Up to six sections may be tested, to collect at least five qualifying strikes with an average that exceeds 95% of the target.

NOTE—It is not required to perform six hits if the average of the first five hits exceeds 95% of target.

The cable and its components shall be inspected with the unaided eye, and material changes, including the metallic tube, shall be documented. If there are broken wires, the numbers and types (aluminum, ACS) of the broken wires shall be reported.

**Tension test after arc:** Upon completion of the five simulated lightning arc strikes, one at a time, each section of OPGW shall be tension tested to MRDT. The sections shall be positioned with the strike location approximately in the center of each section. If requested, a breaking strength test can be performed for information only.

To recognize the practical issues of performing this test, re-testing should be discussed and agreed upon between purchaser and manufacturer.

### **Acceptance criteria**

- a) After the lightning strike application, the cable sample shall experience no permanent increase in optical attenuation greater than 0.10 dB for the concatenated loop at nominally  $1550 \text{ nm} \pm 20 \text{ nm}$  for single-mode fibers.
- b) In all five qualifying lightning strike locations, visually, there shall be no damage (holes, cracks, etc.) to the integrity of the metallic tube.
- c) During the tension test, at least four out of the five qualifying strike locations shall withstand the MRDT for typical applications, or up to a maximum of 70% RTS for special applications. The metallic tube shall maintain integrity after the tension test to MRDT for typical applications, or 70% RTS for special applications.

NOTE—Special applications are considered when MRDT is higher than 70% RTS.

**OBSERVATIONS, IF ANY:**

**TEST RESULT:** The OPGW cable met/not met the acceptance criteria for Lightning Arc test.

**(TESTED BY)**

Sign & Date

**(WITNESSED BY)**

Sign & Date

**TYPE TEST PROCEDURE FOR OPGW CABLE****(17) Test Name: DC Resistance Test****Final Customer: Power Grid Corporation of India Limited, India.****Project Name:****Manufacturer:****Cable Type:****Standard: IEEE 1138-2021 Method 6.5.1.5****Classification:** Cable characteristic/electrical/mandatory**Intent**

The intent of the DC Resistance Test is to determine the actual dc resistance of the cable.

**Objective**

a) To verify that the actual dc resistance of the OPGW cable does not exceed the dc resistance stated by the supplier.

**Set-up and procedure**

Copper connectors shall be crimped or secured to a cable sample approximately 10 m in length, to achieve 5 m gauge lengths. Alligator-type clips, or other suitable connectors, shall be used to connect a calibrated current source of 10 A to the cable.

Optical measurements are not required for this test.

The potential drop between the two points shall be measured by a micro-ohmmeter and displayed directly as micro-ohms. Resistance measurements shall be taken five times in five locations along the 10 m sample length. The dc resistance per meter of the cable shall be calculated by averaging the five individual measurements and dividing by the gauge length. To reduce error due to heating, the current shall be injected through the cable for only a few seconds to obtain a reading. The temperature at the time of testing shall be recorded. If the temperature of the cable at the time of measurement is lower than that specified by the cable manufacturer, then the resistance measurements shall be corrected to the specified temperature.

For shorter cable length samples, alternative set-ups for resistivity measurements that reduces resistivity error such as 4-wire measurement may also be employed, if agreed between the supplier and the purchaser.

**Acceptance criteria**

The actual dc resistance of the OPGW cable shall not exceed the dc resistance stated by the manufacturer at the specified temperature.

**OBSERVATIONS, IF ANY:**

**TEST RESULT:** The OPGW cable met/not met the acceptance criteria for DC Resistance test.

**(TESTED BY)**

Sign & Date

**(WITNESSED BY)**

Sign & Date

## Space for Observations

**IEEE-1138:2021 Clause 6.3**

**Procedure for optical measurements and fiber preparation:**

To increase the sensitivity to changes in attenuation, a number of fibers in each test sample are spliced together, or concatenated, to form one long, continuous optical path. The minimum number of fibers to be spliced and monitored for applicable tests is shown in Table-1. Whenever possible, an equal number of fibers shall be selected from each optical fiber unit.

**Table-4 Minimum Fibers for Tests**

Cable fiber Count	Minimum number of fibers to be spliced and monitored
1 to 24	All
25 to 48	24
49 to 96	36
97 to 192	48
193 to 384	60
385 to 768	72

A laser source with the appropriate wavelength is injected to an optical splitter. The splitter divides the source signal into two signals. During the test, the optical measuring system (source, splitter, and receiver) shall remain stable in a temperature and humidity-controlled environment. One of the split signals is sent directly to an optical power meter and serves as the reference signal. The other split signal is spliced into one of the free ends of the concatenated test fibers. A second power meter is connected to the returning end of the test fibers. This measurement is the test signal. During the tests, the readings from the reference and test optical power meters are monitored and recorded periodically in a suitable manner for future analysis. Any changes from the initial difference between the reference and test signals indicate a change in the attenuation in the fibers due to the test. A net increase in attenuation indicates a loss in the optical signal strength. A net decrease in attenuation indicates a gain in the signal strength.

For tests where the OPGW is subjected to tension, the samples shall be terminated in a manner such that the movements of the end of the optical fibers are restricted relative to the elongation of OPGW cable. Although other arrangements may be used, an example of an arrangement for preparing loops between the test sample and the fiber splice tray is shown in Figure 1. Three loops of cable with a typical diameter of 1 m are formed and secured as close as possible to the dead-end tension clamps. Another three loops of the optical fiber unit only are formed just in front of the splice tray. This configuration is suitable for stranded optical fiber unit cables and will restrain metallic, non-metallic and

fiber components from movement during the test. Other configurations, such as central optical fiber unit cable, may requires a different arrangement.

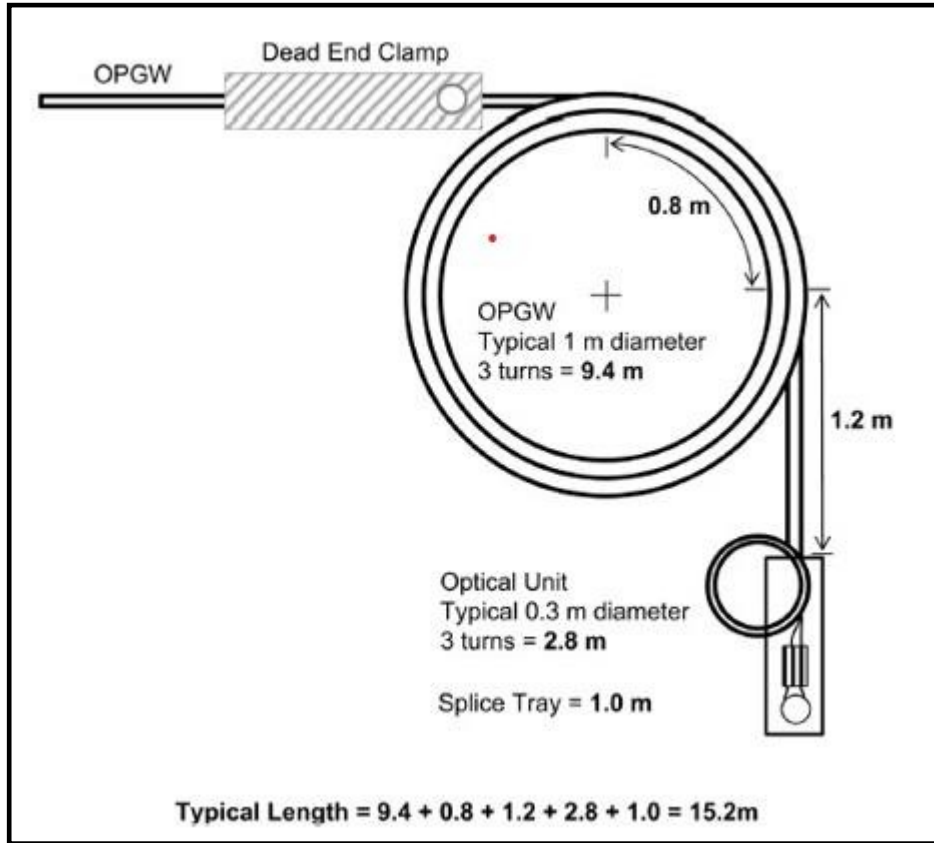

**Figure 7 : Test Sample Termination Arrangement**